

ALLEN TYPE SCREW PLUG

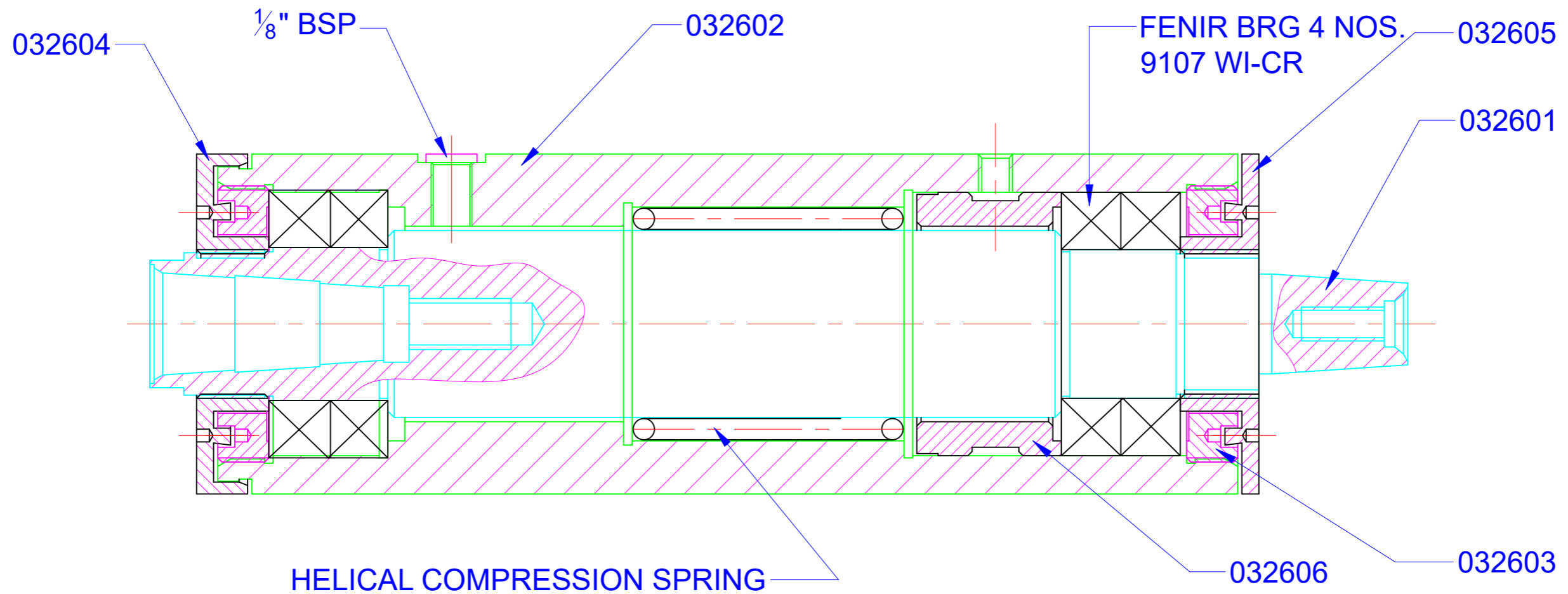

SPINDLE ASSEMBLY

**BILL OF MATERIALS**

| S. NO. | ITEM CODE | PART NAME                      | QTY. |
|--------|-----------|--------------------------------|------|
| 1      | 032601    | SHAFT                          | 1    |
| 2      | 032602    | SLEEVE                         | 1    |
| 3      | 032603    | NUT                            | 2    |
| 4      | 032604    | COVER (LHS)                    | 1    |
| 5      | 032605    | COVER (RHS)                    | 1    |
| 6      | 032606    | BUSH                           | 1    |
| 7      | 032607    | BEARINGS FENIR 9107            | 4    |
| 8      | 032608    | HELICAL SPRING                 | 1    |
| 9      | 032609    | ALLEN TYPE SCREW PLUG 1/8" BSP | 1    |
| 10     | 032610    | PLUG                           | 1    |

LIVE PROJECT DURING TRAINING PROGRAM FOR MECH. ENGINEERS

**SPINDLE ASSEMBLY FOR CNC CYLINDRICAL GRINDING MACHINE**

BABU BANARSI DAS NATIONAL INSTITUTE OF TECHNOLOGY & MANAGEMENT, LUCKNOW

|  |           |           |    |          |
|--|-----------|-----------|----|----------|
|  | TOL.      | APPD      | SG | 27.06.20 |
|  | MAT. : SS | SCALE 1:1 |    | REV. 0   |

**CADPLUS SOFTWARE SOLUTIONS**